

SONY



Intel® Centrino® Mobile Technology

VAIO TX

VGN-TX57GN/B



The power and refinement of black-tie mobility

Specifications

Model	VGN-TX57GN/B
Platform	Intel® Centrino® Mobile Technology • Intel® Core™ Solo Processor U1500 (1.33GHz) ¹ *2 • Intel® PRO/Wireless 3945ABG Network Connection • Intel® 945GMS Express Chipset
Operating System	Genuine Windows Vista™ Business (English version) with Traditional Chinese Language Pack
Processor System Bus	533MHz
Memory Bus	533MHz
Cache Memory	2MB (on CPU)
Main Memory	1GB DDR2 SDRAM (512MB on board, upgradeable up to 1.5GB) 1 SO-DIMM slot
Hard Disk	80GB (HDD recovery storage: 7GB ³ , C: Remain) Ultra ATA/100
Optical Drive	DVD±RW/±R DL/RAM Drive Maximum reading speed: DVD-ROM, DVD+R, DVD-R, DVD+RW, DVD-RW: 8x / DVD-R DL, DVD-R DL: 6x / DVD-RAM: 5x / CD-R, CD-ROM, CD-RW: 24x Maximum writing speed: DVD-R, DVD+R, DVD+RW: 8x / DVD-RW: 6x / DVD-R DL, DVD-R DL: 4x / DVD-RAM: 5x / CD-R: 24x / CD-RW: 16x
Graphics Accelerator	Intel® Graphics Media Accelerator 950
Total Available Graphics Memory (Max)⁴	224MB
Display	11.1" Wide (WXGA: 1366 x 768) TFT colour display (Clear Bright LCD: White LED, Wide View)
Interfaces	• USB 2.0 x 2 • i.LINK (IEEE 1394) S400 (4-pin) • Network (RJ-45) connector (100BASE-TX/10BASE-T) • Headphone jack (stereo mini) • Microphone jack (stereo mini) • Monitor connector (Analogue RGB, mini D-SUB 15-pin) • Modular (RJ-11) connector • Port Replicator connector • Memory Stick slot ⁵ (Standard/Duo Size compatible, MagicGate compatible, Memory Stick PRO compatible, High-speed data transfer compatible) • SD Memory Card slot ⁶ (MMC compatible)
Wireless LAN	• Integrated Wireless LAN IEEE 802.11a/802.11b/802.11g ⁷ • Intel® PRO/Wireless 3945ABG Network Connection • Data rate: maximum 11Mbps (802.11b)/54Mbps (802.11a/g) ⁸ • Frequency: 5GHz (802.11a), 2.4GHz (802.11b/g)
Bluetooth®	• Bluetooth® standard version 2.0 + EDR • Output: maximum +6dBm • Frequency: 2.4GHz
Modem	V.92 and V.90 compliant
Security Chip	TCG ver. 1.2 compliant Trusted Platform Module (TPM)
Fingerprint Sensor	Built-in Fingerprint Sensor
PC Card Slot	Type I/II x 1
Audio	• Intel® High Definition Audio compatible • 3D audio (Direct Sound 3D support) • Built-in stereo speakers
Keyboard / Input Device	• 17mm key pitch / 1.7mm keystroke • 82 keys • Intelligent Touchpad
Battery	VGP-BPSSA ⁹ Lithium-ion battery: up to 9 hours use ¹⁰
Dimensions (W x H x D)	272.4 x 21-28.5 x 195.1mm
Weight	1.25kg (including the supplied battery)
Software Applications	• AV Entertainment: Instant Mode 1.1 • Video Edit/Playback: DVGate Plus 2.3, VAIO Video & Photo Utility 1.0, Adobe® Premiere® Elements 3.0 (Installer), VAIO Edit Components 6.1 (Installer), WinDVD for VAIO 8.0 • DVD Creation: Click to DVD 2.6 • Music: SonicStage CP 4.2, SonicStage Mastering Studio 2.3, SonicStage Mastering Studio Audio Filter 2.3 • Still Image/Photo: Windows® Photo Gallery, Adobe® Photoshop® Elements 5.0 (Installer) • Home Network: VAIO Media 6.0 • Tool: Roxio Easy Media Creator 9.0 (Installer), Adobe® Reader® 7, Norton Internet Security™ 2007 • Utilities: VAIO Control Center 2.0, VAIO HDD Protection 2.0, Infineon TPM Professional Package (Installer), Protector Suite QL 5.3 • Support: VAIO Recovery Utility, VAIO Update 3.0
Supplied Accessories	• AC adapter (VGP-AC16V8) • Lithium-ion battery (VGP-BPSSA) • Headphone (MDR-Q22LP/S02)
Warranty	One year ¹¹

Features and specifications are subject to change without notice.

¹ CPU speed will be reduced under certain operating conditions. ² Intel® Virtualization Technology is not supported on VAIO. ³ Necessary data for recovery (setting back to initial shipment settings) in the hard disk drive consuming approximately 7GB in size is available separately. ⁴ Total Available Graphics Memory refers to the new Windows Vista classification of graphics memory, which is the total of Dedicated Video Memory, System Video Memory and Shared System Memory. ⁵ Compatibility confirmed with Sony branded "Memory Stick" media only. ⁶ The copyright protection and high-speed data transfer features of the SD memory card are not supported. ⁷ The maximum communication distance can vary depending on the obstacles or the distance between the communication devices, the radio waves, the operating system or the software being used. ⁸ The communication speed varies depending on the distance between communication devices, existence of obstacles between such devices, the device configuration, the radio conditions, and the software in use. In addition, communication may be cut off depending on the radio conditions. ⁹ This product may only function with a genuine Sony battery designed for this model. ¹⁰ Estimated battery life (under JEITA Battery Run Time Measurement Method ver. 1.0). When the power-saving mode is on. Actual battery life may vary with different operating conditions and settings. For further details, please visit vaio-online.sony.com ¹¹ Warranty conditions may vary by region.

The trademarks, including but not limited to "SONY", "VAIO", "Memory Stick" and "SonicStage" are either trademarks or registered trademarks of Sony Corporation and/or its subsidiaries. Adobe, Adobe Photoshop, Adobe Reader and Adobe Premiere are trademarks of Adobe Systems Incorporated in the United States and/or other countries. Intel, the Intel logo, Centrino and the Centrino logo, Intel Core and Core Inside, are trademarks or trademarks of Intel Corporation or its subsidiaries in the United States and other countries. Windows, Windows Vista and the Windows logo are trademarks or registered trademarks of Microsoft Corporation in the United States and/or other countries. All other product and brand names may be trademarks or registered trademarks of their respective owners. Whilst information given is true at time of printing, small production changes in the course of our company's policy of improvement through research and design might not necessarily be included in the specifications. E&OE. Actual models may differ slightly in appearance to illustrations provided.

Sony recommends Windows Vista™ Business.

VGN-TX57GN/B

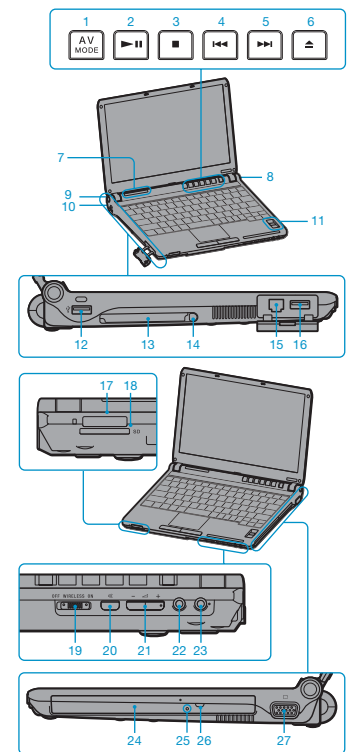

1. AV Mode button
2. Play/Pause button
3. Stop button
4. Previous track button
5. Next track button
6. Disc eject button
7. Indicators
8. Network (RJ-45) connector (100BASE-TX/10BASE-T)
9. DC-IN connector
10. i.LINK (IEEE1394) S400 (4 pin) connector
11. Fingerprint sensor
12. USB 2.0 connector
13. PC Card slot (Type I/II x 1)
14. PC Card eject button
15. Modular (RJ-11) connector
16. USB 2.0 connector
17. Memory Stick slot (Standard/Duo Size compatible, MagicGate compatible, Memory Stick PRO compatible, high-speed data transfer compatible)
18. SD Memory Card slot (MMC compatible)
19. Wireless LAN switch
20. Mute button
21. Volume buttons
22. Headphone jack (stereo mini)
23. Microphone jack (stereo mini)
24. DVD±RW/±R DL/RAM Drive
25. Manual eject hole
26. Disc eject button
27. Monitor connector (Analogue RGB, mini D-SUB 15-pin)

Optional Accessories for VGN-TX57GN/B (availability depends on region)

VGP-PRTX1
Port Replicator

- DC-IN
- Monitor connector (Analogue RGB, mini D-SUB 15-pin)
- Network connector
- USB 2.0 connector (x3)

VGP-CP5
Carrying Pouch

- Urethane lining prevents scratches
- Embossed VAIO logo
- Mini pouch included
- Convenient Velcro closure

VGP-BMS33
Silver (S), Black (B)
Bluetooth® Laser Mouse

- Smart wireless mouse for mobile use
- Highly accurate laser sensor
- Innovative PTFE sole for precise operation
- Sensor resolution: 800 dots per inch

VGP-BPL5A
Lithium-ion Battery (L)

- Rechargeable battery
- Up to 14.5 hours battery life¹⁰

VGP-CKTX1
Carrying Case

- Perfect size for VAIO TX
- Ideal slim, lightweight PC case
- Seven layer cushioning fabric
- Soft, luxurious feel in hand

VGP-WMS50A
Wireless Presentation Mouse

- Presentation mode for smarter presentations
- Ergonomic design naturally fits your hand
- Innovative PTFE sole for precise operation
- Sensor resolution: 800 dots per inch

vaio-online.sony.com

like.no.other

VAIO
no more bounds





Portable business empowerment and pleasure VGN-TX57GN/B

You'd never guess from the sleek, elegant body that VAIO TX57GN/B is simply bursting with advanced functionality. Its user-friendly features include entertaining AV offerings, leading security measures that protect your data, the new Windows Vista™ operating system and built-in wireless capabilities that set your productivity free. Whether you're in the office or on the go, VAIO TX57GN/B's sapphire black carbon fibre body panels sharpen your image, while impressive Intel® Centrino® Mobile Technology empowers you to succeed. With VAIO TX57GN/B, you'll always enjoy a competitive advantage.



Comfortable keyboard



Frontal headphone jack
Convenient Mute button and Volume buttons
Convenient fingerprint recognition



Unique AV buttons



VAIO mirror logo in black

Sony recommends Windows Vista™ Business.



The sophisticated appeal of a sleek, chic sports car

With smooth lines and a sleek overall design, the VAIO TX57GN/B has the elegance of a well-crafted sports car. Sapphire black casing crafted from carbon fibre blends a sharp, slight profile with lightweight resilience. The use of white LEDs adds visual appeal to the display cabinet. The VAIO TX57GN/B also incorporates a unique "gravity-joint" between the ultra-slim display and the keyboard — imparting a distinct sense of balance that adds confidence to the entire user experience.

Powerful mobility

The VAIO TX57GN/B gives you powerful performance on the move. Its VGP-BPS5A battery delivers up to 9 hours* of productivity, while the optional VGP-BPL5A battery delivers up to an impressive 14.5 hours*. Proven performance is underscored by impressive Intel® Centrino® Mobile Technology comprising an Intel® Core™ Solo Processor U1500 (1.33GHz), an Intel® 945GMS Express Chipset and Intel® PRO/Wireless 3945ABG Network Connection. Wireless LAN a/b/g capability is built-in as standard, and Bluetooth® headset support adds versatile communicative capability.

* Estimated battery life under JEITA Battery Run Time Measurement Method (ver. 1.0) when the power-saving mode is on. Actual battery life may vary with different operating conditions and settings.



Recommended headset
Sony Ericsson HBH-PV705*
* Availability depends on region.

Security for assured mobility

VAIO TX57GN/B has many security features to prevent unauthorised access and ensure your mobile PC lifestyle. Hard Disk Password protects sensitive HDD data for one level of security. The biometric fingerprint sensor allows for another, with easy yet unmistakable ID recognition, circumventing the need for passwords. Further data protection for your VAIO TX57GN/B comes from secure encryption and decryption of files and folders via the Trusted Platform Module (TPM) security chip and bundled software utility.

An excellent 11.1" wide AV experience

Despite being so surprisingly slim, the VAIO TX57GN/B is big on entertainment. Employing white LEDs for the backlight, the 11.1" wide LCD (16:9 / WXGA: 1366 x 768) delivers excellent DVD viewing performance beyond its weight and dimensions. Instant Mode can be activated at the press of a button, so you can enjoy CDs and DVDs without waiting to boot up. Furthermore, the SonicStage Mastering Studio Audio Filter enables excellent audio production through recommended headphones (for example, MDR-Q22LP/S02 supplied with VAIO TX57GN/B). DVD±RW/±R DL/RAM writing capability adds to options for creative output. Impressive, entertaining, inspiring — that's the VAIO TX57GN/B.



Supplied open-air, overhead headphones
MDR-Q22LP/S02

Powerful software for creative minds.

DVD CREATION

With Click to DVD, you're only a click away from creating your own photo, movie + photo, or video DVD on DVD±RW/±R DL or DVD-RAM disc. You can also create 5.1 surround sound DVDs. Moreover, Roxio Easy Media Creator 9 lets you back up audio, image, and data files on CDs and DVDs.



Click to DVD Roxio Easy Media Creator 9

VIDEO & PHOTOS

VAIO Video & Photo Utility makes it easier than ever to import and export many kinds of AV files. VAIO Content Importer simplifies the import of videos and photos from various sources, including Handycam®, Cyber-shot®, and DLNA server. You can then edit your video footage with Adobe® Premiere® Elements and your still images with Adobe® Photoshop® Elements. After editing, data can easily be burned on a DVD or exported to a Memory Stick with VAIO Content Exporter, letting you fully enjoy your digital lifestyle.

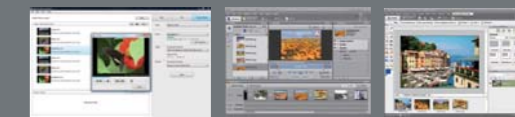

VAIO Video & Photo Utility Adobe® Premiere® Elements Adobe® Photoshop® Elements

MUSIC

Import music from the Net or CDs with SonicStage CP. Then transfer it to a Walkman® or burn your own original CDs. SonicStage Mastering Studio lets you import analogue music (Roland EDIROL AUDIO capture UA-25* or UA-101* USB audio interface device required) and edit it with high-quality effector modules before recording on a CD. SonicStage Mastering Studio Audio Filter can enhance any sound played on VAIO and provides excellent headphone presets.



SonicStage CP SonicStage Mastering Studio SonicStage Mastering Studio Audio Filter

✦ Main features

DVD video recording: One-Click DVD Video Creation	4.5mm slim display: Clear Bright LCD (White LED, Wide View) / Wide 16:9	Ultra light weight: 1.25kg	Network freedom: Wireless LAN 802.11 a/b/g	Cable-free: Bluetooth®	Superior material: Carbon Body	Handy presentation: Plug & Display
Instant ID recognition: Fingerprint Sensor	Assured security: TPM Security Chip / Hard Disk Password	Scratch prevention: VAIO HDD Protection	Content sharing: Memory Stick Slot (Standard/Duo/MagicGate/PRO compatible) / SD Memory Card Slot	Simple entertainment access: AV Control Buttons	Optional accessory: Port Replicator	

✦ Basic specifications

Intel® Core™ Solo Processor U1500 (1.33GHz)	Genuine Windows® Vista™ Business	11.1" WXGA 1366 x 768 LCD	DVD±RW/ ±R DL/RAM Drive	1GB (DDR2) Main Memory	80GB Hard Disk Drive
---	--	------------------------------	----------------------------	---------------------------	-------------------------



* Availability depends on region.
Note: Any copying or reproduction of copyrighted material may amount to copyright infringement. Song titles, names of artists and other information shown in the SonicStage screen capture are provided for illustrative purposes only.